

# Full-HD Integrated Pan-Tilt HD/SD Camera Capable of IP Image Monitoring

HD Integrated Camera

For indoor use

## AW-HE60S [SDI Model]

HD Integrated Camera

For indoor use

## AW-HE60H [HDMI Model]

Full HD  
MOS

18x  
optical zoom

HD/SD

IP/Serial  
control

DRS

Turn-lock  
mounting  
mechanism

Night  
mode

IP  
monitoring

**HD** 1080/59.94p<sup>1</sup>, 59.94i, 50p<sup>1</sup>, 50i, 29.97PsF, 25PsF, 720/59.94p, 50p

**SD** 576/50p<sup>2</sup>, 50i, 480/59.94p<sup>2</sup>, 59.94i

\*1 AW-HE60H HDMI output only

\*2 AW-HE60H only



Suspended (Hanging) style

Stand-alone (Desktop) style

**HDMI™**  
HIGH-DEFINITION MULTIMEDIA INTERFACE  
(AW-HE60H only)

Option



Wireless remote control  
**AW-RM50G**

("AA", "R6" or "LR6"  
battery x 2 are not included.)



Direct Ceiling Mount Bracket  
**WW-Q105**

Multi-interface Cable **AW-CA20T6G**

### System example

#### HD/SD Camera System

**For small or medium scale shooting, such as education, business and wedding applications**

**Key Points**

- Up to 100 x AW-HE60S units can be controlled by AW-RP50 via IP connections through Ethernet hubs.

**[Key Products]**

AW-HE60S AW-HS50 AW-RP50

Optimal for both hanging and desktop installation.

The mounting bracket and drop-prevention wire are standard accessories. Ceiling and desktop installation are both possible. Mount the bracket onto the installation surface and then put and turn the main unit on the bracket to be installed.

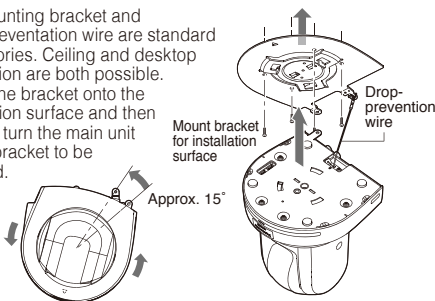

\* Wiring, mounting, and removal must be done by a qualified technician. To ensure safety, consult with the dealer from whom you purchased the system.

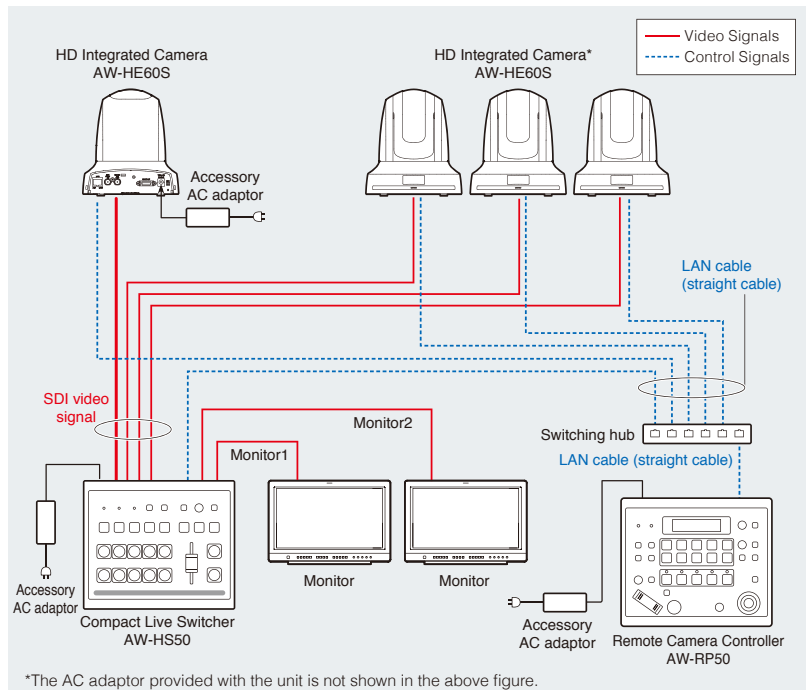

\*The AC adaptor provided with the unit is not shown in the above figure.

## Camera, lens and pan-tilt in one compact, lightweight body

The lineup consists of two models, the AW-HE60S SDI model, which is optimal for content production, and the AW-HE60H HDMI model, which is ideal for image distribution in applications such as videoconferences. In addition to IP control, both models can be connected to existing controllers with serial control. An attractive form that blends with its surroundings and a cable cover that minimizes clutter allow shooting without adversely affecting the mood of the installation location.



## 1/3 type Full-HD MOS sensor and high-performance zoom lens

The cameras are equipped with the 1/3 type Full-HD MOS sensor and digital signal processor (DSP). Shooting clear, crisp HD video even in environments with less light (minimum illumination of up to 3 lx). In addition to the 18x optical zoom lens, the camera features a 10x digital zoom. This makes it possible to shoot a wide variety of sharp and crisp images, from wide angle to close up face.



From wide angle to telescopic shots - the cameras deliver clear and crisp images for a wide range of applications. (Images are simulated.)

## Dynamic Range Stretch (DRS) automatically optimizes images that have a wide contrast range.

### ● Dynamic Range Stretch (DRS)

A gamma curve and knee slope are estimated to match the contrast of each pixel in real time. When dark, bright, and intermediate areas are all contained in the same scene, this function produces excellent gradation for each area and minimizes blocked shadows and blown highlights. The images of results are enhanced by a visually wider dynamic range.

### ● Hybrid (2D/3D) Noise Reduction

The Hybrid (2D/3D) Noise Reduction function also suppresses afterimages, even in difficult lighting conditions.

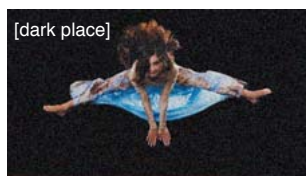

**Without Noise Reduction**  
Some noise appear when gain control is turned up

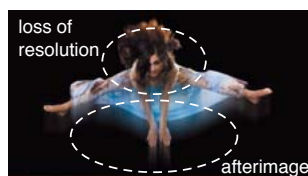

**3D Noise Reduction Alone**  
Afterimage and some loss of resolution appear



**The Hybrid (2D/3D) Noise Reduction**  
Clearer images in difficult conditions

(Images are simulated.)

## Equipped with Night mode for infrared shooting

When an optional infrared illuminator is used in conjunction with Night Mode, the camera can deliver high quality monochrome images in the dark.

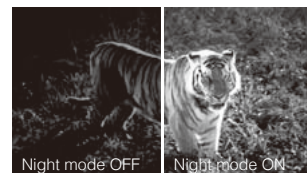

(Images are simulated.)

## IP Control with Image monitoring

### ● IP control for easy connection and setup

IP connection allows control of up to 100 x AW-HE60S/H units from an AW-RP120G, AW-RP50 or a PC via switching hubs. IP connection also allows one AW-HE60S/H to be controlled simultaneously from up to five AW-RP120G and AW-RP50 units.

### ● IP image monitoring\*1 supported

Features an image compression and IP image transmission LSI. The IP image output function\*2 allows transmission of images from one camera to up to 14 terminals through IP networks.\*3 When combined with IP control, the camera can be controlled from a distant location.



Live screen



Multi screen

\*1 For more information, see page 18

\*2 Video output and IP image output signals cannot be used simultaneously.

\*3 The number varies depending on distribution settings.

Only one Android™ device can be connected to one camera.

## Other features

### ● Pan-tilt mechanism for smooth movement

The pan range of  $\pm 175^\circ$  and the tilt range of  $-30^\circ$  to  $90^\circ$  cover a wide shooting area. The pan and tilt operate at a maximum speed of  $90^\circ$ /second and respond quickly to remote control operation. They operate quietly at a sound level of NC35 or lower.

\* Depending on the position of the pan and tilt, its own unit may be reflected in the images.

### ● Setting camera menus with a PC

Camera menus can be set up via a web browser by connecting the AW-HE60S/H to a PC.

### ● Wireless remote controller for easy operation (option)

Up to 4 cameras can be controlled by an optional wireless remote controller (AW-RM50G). The basic operations and menu settings can be done by using the wireless remote controller.

### ● Simple connection and installation enable a flexible camera layout.

IP control, a lightweight body, and the turn-lock mounting mechanism enable easy connection and mounting by a single person.

### ● Compact design for energy-saving

The compact, lightweight body realizes low power consumption and low cost operation of multiple cameras.

### ● Allows up to 100 pre-set memories per camera